

# Advances in Sensors and X-ray Spectroscopy for Agricultural Soil Analysis

Paulo E. Cruvinel

Embrapa Instrumentation, São Carlos, SP, Brazil

Post-Graduation Program in Computer Science - Federal University of São Carlos, SP, Brazil

Email: paulo.cruvinel@embrapa.br

**Abstract**— This paper presents a study regarding sensors development and the use for X-ray spectroscopy. In fact, we include not only a novel discussion on sensors since the X-rays discovery, but we also present a prospective about the future. X-ray-based spectrometry is an analytical technique to determine the elemental composition of different materials. For agricultural soils, either soft or hard X-ray spectroscopies have been shown to improve agronomic competitiveness and agroecosystems sustainability. This review in X-ray sensors considers their use in both X-ray fluorescence and particle induced X-ray emission techniques, i.e., highlighting new materials, accuracy, resolution, efficiency, energy response, and related methods.

**Keywords**—X-ray Sensors; Radiation-matter Interaction; Spectrometer; Intelligent Instrumentation; Soil analysis; Decision making.

## I. INTRODUCTION

Currently, it is possible to estimate that agriculture represents around 3 trillion USD of the global economy. This considers the planet's growing population, the increased interest by consumers in the origins and quality of food, and challenges brought on by climate change, sustainability, and circular economy. Besides, it is becoming clear that the future of agriculture relies on technology and on technological advancement. In fact, the world already has experienced four waves of agricultural technologies, i.e., Mechanization (first wave, 1700–1940s); Agricultural chemistry, biochemistry, and genetics (second wave, 1940s–1990s), which has included synthetic fertilizers, pesticides for pest control, and Genetic Modified Organisms (GMOs), created through genetic engineering and available to consumers; and Precision farming (third wave, 1990s–2014), that brought the huge use of Global Positioning System (GPS), smart sensors and instrumentation to support decision making in agriculture. However, beyond that, in recent times, the agricultural world has been using advanced sensor-based methods on the interaction of the electromagnetic radiation with matter, as well as big data and artificial intelligence, all to better understand and manage the complex system soil-plant-atmosphere, i.e., not only for gain in production, but also looking for non-invasive operation and the resilience of the ecosystems [1][2]. Such a scenario has become the newest wave in the agricultural industry.

In the context described above, technology development and innovation lead farming operations to be more productive, harvesting more crops per area and yielding higher quality products. In such a context, non-invasive

sensors play a vital role in this technological revolution [3]. For example, sensors in a smart agriculture technology are essential in the measurement of soil pH, which is related to the availability of nutrients and essential to plant growth. In addition, Global Positioning System (GPS) sensors, which are typically associated with tractors and other machineries, including wireless communication on farms, are useful for plant harvesting and related farming techniques, including highly precise machine guidance systems, i.e., reducing process overlap and the amount of time required to complete and optimize management tasks [4]. Likewise, temperature sensors based on the use of infrared radiation are crucial for ambient condition monitoring and mechanical asset monitoring. Similar to the use of temperature sensors in predictive maintenance, wireless accelerometers are being widely utilized to predict and assist with required maintenance. Primarily used on moving components and motors, the wireless accelerometers detect slight variations in movement and vibration inconsistencies and predict when standard maintenance is required, which is quite useful to prevent failure and improve reliability [5]. Such accelerometers are also used in a variety of automated systems and tracking methods, such as, for instance, to monitor the status of an adjustable spray nozzle on the end of a fertilization beam. In more recent applications, they also have been used with Unmanned Aerial Vehicles (UAVs) for inertial measurement, i.e., to track motion, speed, undesirable events, and position in space [6].

Further, the use of smart cameras operating in several bands of frequencies (multispectral or even hyperspectral) has been adopted for a variety of smart agriculture applications, i.e., to detect either crop vitality or even families of weeds and other plant locations to automatically and accurately decrease the use of herbicides and improve sustainability.

Furthermore, for soil quality evaluation, it is advantageous to have a large availability of sensors that are able to detect a set of elements and allow their measurement in a wide range of concentration values [7]. Such elements play an important role for plant growth. Actually, many of these elements have a quite well-known function with plant uptake, while others are still under investigation and demand scientific research. In such a context, the current elements that can be observed from an agricultural soil are macronutrients such as nitrogen (N), phosphorus (P), potassium (K), sulfur (S), calcium (Ca), and magnesium (Mg), as well as micronutrients, such as boron (B), chlorine (Cl), copper (Cu), iron (Fe), manganese (Mn), molybdenum (Mo), nickel (Ni), and zinc (Zn), all of which are based on

natural resources or come from soil inputs, like fertilizers. To obtain such information, it is necessary to perform soil analysis, which is a valuable tool for food production as it determines the inputs required for efficient and economic production. A proper soil analysis will help ensure the application of enough fertilizer to meet the requirements of the crop while taking advantage of the nutrients already present in the soil. It will also allow the farmer to determine lime requirements and can be used to diagnose problems in the crop areas. Soil analysis is a requirement for farms that must complete a nutrient management plan.

Currently, there are several techniques available for soil chemical analysis [8]. The most common ones are spectrophotometry in the uv-visible and colorimeters, atomic absorption spectrophotometry, atomic emission spectrophotometry, inductively coupled plasma and High-Performance Liquid Chromatography. However, despite being efficient, most of them have a high cost, not only in terms of instrumental infrastructure, but also in relation to sample preparation, which in general is based on chemical processes. Also, the analysis is highly time consuming, which is a critical factor.

Based on the reasons mentioned above, the use of ionizing radiation for X-ray spectroscopy, which also allows elemental analysis of soil samples, has been considered even more for scientific research and innovation for soil analysis.

Soil analysis is the only method that allows, before planting, to identify the ability of the soil to provide the nutrients that are needed by plants, in addition to having a basis for recommending the necessary amounts of correctives and fertilizers to intensify crop productivity and, consequently, obtain the best return on investments and increased profit. When carrying out the soil analysis, the producer also allows monitoring the changes in the fertility of the production area. This is because it offers the possibility of increasing production and plant resistance, reducing expenses with pesticides (insecticides, herbicides and fungicides) and consequently, also promoting a reduction in environmental impacts.

The intelligent agriculture industry is expanding quickly, presenting new solutions to farmers practically daily. Methods and devices aggregate sensor data, relay critical information to farmers and are focused on the optimization of the agricultural processes for food, energy and fibers production.

This paper presents advances in sensors and potential applications in X-ray spectroscopy for analysis, i.e., based on the applications of both X-ray Fluorescence (XRF) and Particle Induced X-ray Emission (PIXE) in agriculture.

The rest of the paper is structured as follows. Section II presents the evolution of sensors for these two case studies, as well as their state-of-art and future prospective. Conclusions are presented in Section III.

## II. SENSORS FOR XRF AND PIXE

X-rays were discovered in 1895 by the German scientist Wilhelm Conrad Röntgen [9]. These rays could pass through the heavy paper covering and exciting phosphorescent materials. One of Röntgen's first experiments late in 1895

was the use of a photographic film as a sensor. Current radiographic films are based on polyethylene terephthalate (polyester). The Roentgen's discovery led to the development of the X-Rays Fluorescence (XRF) spectroscopy which has become a powerful and versatile technique for the analysis and characterization of materials. Pioneering work in XRF has been led by William Lawrence Bragg and William Henry Bragg [10]. This work distinguishes different elements present in a sample according to the characteristic X-ray energies they emit and helps in determining their respective concentrations. Figure 1 presents a basic arrangement for a typical XRF instrument.

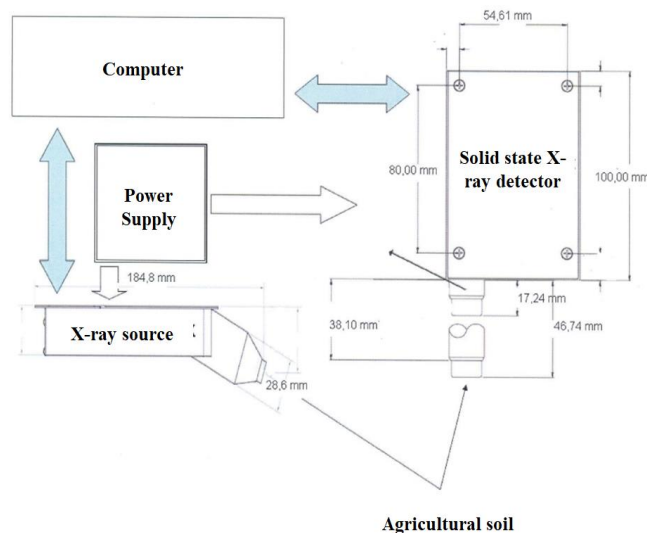

Figure 1. Instrumental arrangement for a typical XRF spectrometer.

In fact, X-ray spectroscopy is a technique that detects and measures photons of light that have wavelengths in the X-ray portion of the electromagnetic spectrum. There are different X-ray spectrometers configurations and associated methods that can be used for several disciplines and fields of application. In 1996, Pessoa and co-authors presented one of the first arrangements based on XRF for agricultural soil and plant analysis [11].

More recently, the definition for XRF has been expanded to include the study of the interactions between particles such as protons, electrons, and ions, as well as their interaction with other particles as a function of their collision energy. In such a context, one may use particles and their acceleration for the ionization of the atoms of a sample with subsequent X-ray emission, characteristic from the present elements, i.e., a technique named Particle Induced X-ray Emission (PIXE). The number of X-ray photons of a given element provides information on the quantity of that element. Pioneering work in PIXE has been first proposed in 1970 by Sven Johansson of Lund University, Sweden, and developed over the next few years with his colleagues Roland Akselsson and Thomas Johansson [12]. With this technique, samples can be analyzed with weight in the order of 10-12 g for solids and volume in the order of 1 mL for liquids. Such a technique allows the simultaneous detection of all elements

with an atomic number above Mg, and the inorganic matrix of the sample during its preparation for analysis is maintained. Figure 2 illustrates a typical arrangement for PIXE analysis.

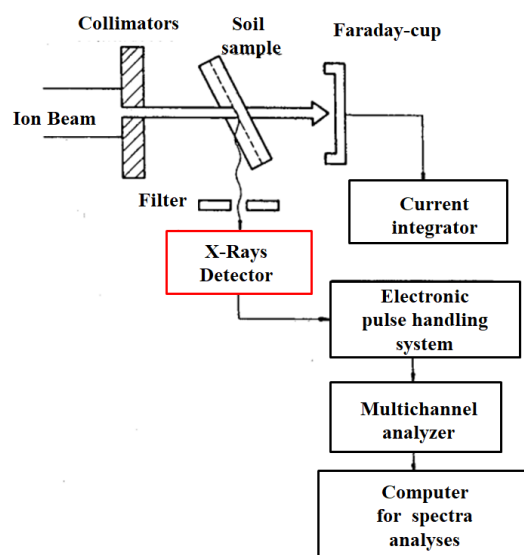

Figure 2. Instrumental arrangement for PIXE analysis.

In 1993, Cruvinel and Flocchini presented the first arrangement based on PIXE for agricultural soil analysis [13]. PIXE has allowed a very quick soil analysis. For instance, considering the X-ray induction by 4.0 MeV protons, the emergent X-rays have been obtained using the cross section as a function of the ionization energy, and the analysis of a set of soil samples was carried out. Further, additional arrangements using a particle accelerator either like a Cyclotron or a Pelletron, and an alpha source have allowed accurate analyses and configuration of portable PIXE instruments [14]. In fact, for both XRF and PIXE techniques in the quantitative analysis of agricultural soils, corrections are required, for the diameter size of the particles or aggregates of a certain composition. In addition, corrections are required for X-ray transmissions through filters, which are used with sensor-based detectors.

For the X-ray sensors, a significant evolution has been observed since the first experiment organized by Röntgen in 1895 using a photographic film. The Röntgen's original method remained important because it was widely available. In the 1900s and the 1910s, several rival techniques of chemical coloration evolved which were easier to use because no development was required. The discoloration of pastilles left on a body receiving radiotherapy would by comparison with a color chart give a measure of the dose applied. Such techniques were good enough if the precision required was not great. The rational radiotherapy of the 1920s required greater precision, however, driving the development of instrumentation that required no judgment by the human eye. The instrument eventually chosen was an elaboration of that with which Ernest Rutherford and the Curies had conducted their experiments in radioactivity [15].

The idea was that radiation ionized air in a chamber and the ions were counted by measuring the current they produced across an electric potential. However, this was greatly dependent on the size of the chamber and the material of the walls, and also on the relative positions of the X-ray tube and chamber, and it was not until 1928 that an international X-ray intensity standard was fully accepted, a standard that specified the behavior required to achieve the required precision. For the first time, X-ray researchers had confidence that numbers could be compared between laboratories [16], i.e., considering metrological bases aspects.

New X-ray detectors are being developed since the 1940s, with the emergence of proportional and scintillation counters and the electronics needed for signal processing. With an extensive use of tubes, solid-state counters have also been incorporated since they are less expensive, have high collection efficiency and there is no need for moving parts.

The smaller counters have not only enabled portability in the 1980s, but also improvements in the analytical techniques related to XRF and PIXE. In fact, there are different detectors, especially based on single crystals [17]. For the X-ray detectors, many corporations can make their commercially available ones, including Silicon (Si) photodiodes, and Charge Coupled Devices (CCD) cameras, among others. In the low energy X-ray region called the soft X-ray region from a few hundred eV to about 20 keV, direct detectors such as Si PIN photodiodes (PIN layers: P, I, and N, where the P-layer is doped with a trivalent impurity, and its terminal acts like anode, the I-layer is undoped or very lightly doped, and N-layer is doped with a pentavalent impurity, and its terminal acts like cathode), Si with the transistor Active Pixel Sensors (Si APS), and CCD area image sensors are utilized. The PIN structure allows high quantum efficiency and fast response for detection of photons in the 400 nm to 1100 nm range [18]. All of these X-ray detectors can provide high energy efficiency and high energy resolution and can be useful for elemental analysis of agricultural samples. On the other hand, for the hard X-ray region with energy higher than 20 keV is sensors based on high penetration efficiency through samples or objects are utilized. For such a context, scintillator detectors are still widely used, i.e., they are able to convert X-ray into visible light and detect this visible light to detect the X-ray indirectly. Likewise, one may find expressive diversity in the X-ray detectors currently in use for spectrometers; however, the majority of these are already semiconductor-based detectors. This occurs because of the outstanding combination of high speed, spatial resolution, and sensitivity, as compared to other types of detectors, such as those based on gas and photomultiplier tubes with single crystals [19].

As we have seen, the use of semiconductor materials to detect electromagnetic radiation has been developed extensively during the last forty years [20]. Within this period, for instance, the Lithium Silicon (Si(Li)) detector [21] of a particular shape and size has been the preferred choice for detecting low energy X-rays. These include XRF systems, among other applications. Within the last years [22], it has become known about the usefulness of

Germanium (Ge), as well as its advantages in relation to the use of Si. However, even though the technology based on the use of Ge is known for X-ray detectors, there are still customization and development needed for a wider range of experiments based on the use of high energies, such as those required in imaging. In fact, major attention has been employed for the development of these Ge detectors as devices for high resolution energy dispersive XRF.

Gallium arsenide (GaAs) is also used in diodes, Field-Effect Transistors (FETs), integrated circuits, as well as for X-ray sensors. For such devices, the charge carriers, which are mostly electrons, move at high speed among the atoms. This makes sensors based on GaAs components useful at ultra-high frequencies. GaAs devices generate less noise than most other types of semiconductor components [23].

On the other hand, Cadmium telluride (CdTe) is also a semiconductor with favorable characteristics for spectrometer-based X-ray detectors. The band gap is sufficiently large so that only moderate cooling is required to obtain small leakage currents. The high density and high atomic numbers (Cd with  $Z=48$ , and Te with  $Z=52$ ) result in efficient photoelectric absorption. This high- $Z$  semiconductor material provides excellent stopping power, resulting in superior detection efficiency even at high X-ray energies. The manufacturing quality and the availability of Schottky contacts allow achieving adequate energy resolution over one useful workable range. The detrimental spectral tailing due to the comparatively short lifetime can be limited by applying large bias voltages. As an example, the CdTe thickness of  $1000\ \mu\text{m}$  provides high quantum efficiency up to  $100\ \text{keV}$ , and it can be capable of operating high X-ray fluxes [24].

In addition, in terms of the state-of-the-art and the future, it is possible to find commercially available Silicon-Drift-Detector (SDD), which incorporates two different design concepts, one based on an integrated FET and the other based on a discrete external FET [25]. Figure 3 shows a typical relation between efficiency and energy for the SDD. The performance of the SDDs provided by these two technologies can provide advantages and disadvantages, depending on the application and needs.

Figure 4 illustrates, as an example, the evaluation of a high-performance semiconductor sensor that operates with a resolution in the order of  $145\ \text{eV}$  in a wide working region, i.e., from  $4\ \text{keV}$  to  $30.0\ \text{keV}$ .

The SDD sensor with integrated FET considers integrating the FET into the sensor design as part of the anode assembly. This way, the capacitance of the anode-FET combination can be minimized. Besides, the high resistivity material used is very different from the lower resistivity material that has typically been used to optimize gain and noise for discrete FETs. Therefore, since it has lower voltage noise, a good resolution can be achieved at the minimum possible process time with the highest possible count rate. However, in such a set-up, part of the sensor is susceptible to irradiation by incident X-rays and the electrostatic fields surrounding the FET result in performance losses at low energies. To overcome this issue, the shape of the sensor can

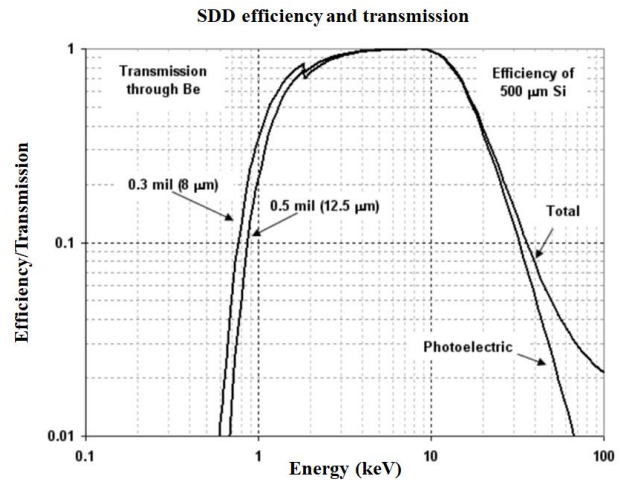

Figure 3. Efficiency versus energy for a typical Silicon Drift Detector (SDD).

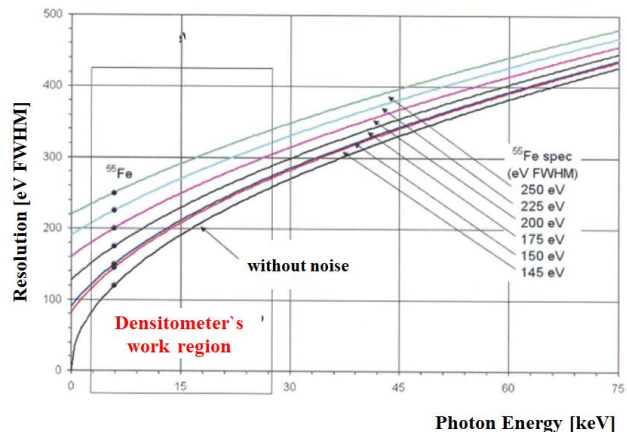

Figure 4. An example for one solid state sensor working region evaluation based on  $145\ \text{eV}$  resolutions.

be re-designed to place the anode and FET at the margins protected by a collimator. Likewise, the drift rings are designed in a tear-drop shape so the electrons drift towards the anode.

The SDD sensor with a discrete external FET uses a dedicated feedback capacitor and a well-proven method of pulsed charge restoration. This allows stability and provides more accurate X-ray measurement. It also means FETs can be designed and manufactured separately and the materials can be chosen to maximize their performance. The advantage of this arrangement is that the bonding between anode and FET introduces higher capacitance than with integrated designs. Therefore, the speeds at which the best resolution can be achieved are lower, although still much faster than what can be achieved with Si(Li). Such a sensor can also provide reduction on the rise time effects, and excellence in low energy performance even with large area sensors.

Beyond the SDD detectors, one prospective opportunity for the future is related to the use of conductive polymers for X-ray sensors. Conductive polymers present numerous

advantages such as high sensitivity, short response time, room temperature operation, and the possibility of tuning both chemical and physical properties by using different substituents [26][27]. Therefore, sensors based on conductive polymers and their composites have attracted much attention from researchers. The conductive polymers used for sensors mainly consist of polyaniline, polypyrrole and poly (3,4-ethylenedioxythiophene), among others. In fact, conductive polymers composites combine different advantages in relation to other sensing materials such as carbonaceous materials, metal oxides, as well as they may lead to both high sensing characteristics and performance due to the synergistic effect of the components.

Furthermore, the field related to X-ray sensors for spectrometry is still under a promise revolution, i.e., there are challenges related to the improvement in multiple energies response and resolution, size, non-invasiveness, operation at room temperature, low-power consumption, reliability, detectable limit, and methods for customization based on the application, among other aspects. Despite that, it is also important to observe that sensors are only one important part of a spectrometer into the analysis chain. The nuclear pulse processor and the additional electronics associated with the software design are equally important to achieve a reliable system not only for high but also for low count rates.

### III. CONCLUSIONS

Even though different detectors are widely used in X-ray spectrometry, there are still challenges related to the need for improvements for both soft and hard X-ray detection. For such matter, several studies have been performed in the last decade, all of which are looking to new possibilities for advanced X-ray detection based on new materials and intelligent electronics for signal processing, and other decision-making computational support related developments. As shown, a new line of spectrometry and related methods have been generated focused on agricultural demands and analysis, i.e., related to food production and environmental protection. The concepts of physics and the analysis tools available or developed by various branches of knowledge and engineering have allowed advanced use of XRF and PIXE in agricultural sciences. One challenge is linked to the integration and interpretation of the results at different scales

Another major challenge requiring continuous scientific and instrumentation effort is the development of on-the-go and portable X-ray sensors-based spectrometers, which can be taken to the field to carry out in-situ measurements. These could allow not only the measurements of stationary elemental concentration values, but also dynamic studies in relation to soil nutrients availability and uptake by plants. In addition, they could help with real-time soil fertilization at a variable rate based on the use of precision agriculture concepts.

### ACKNOWLEDGMENT

This research was partially supported by the Brazilian Corporation for Agricultural Research (Embrapa).

### REFERENCES

- [1] M. K. Sott et al., "Bibliometric network analysis of recent publications on digital agriculture to depict strategic themes and evolution structure", *Sensors*, vol. 21, pp. 7889-7916, 2021.
- [2] M. Liebman and L. A. Schulte, "Enhancing agroecosystem performance and resilience through increased diversification of landscapes and cropping systems", *Elementa: Science of the Anthropocene*, vol. 3, pp. 000041-000048, 2015.
- [3] G. Agati et al., "In field non-invasive sensing of the nitrogen status in hybrid bermudagrass (*Cynodon dactylon* × *C. transvaalensis* Burt Davy) by a fluorescence-based method", *European Journal of Agronomy*, vol. 63, pp. 89-96, 2015.
- [4] Z. Zhai et al., "Decision support systems for agriculture 4.0: Survey and challenges", *Computer and Electronics in Agriculture*, vol. 170, pp. 1052-1057, 2020.
- [5] P. E. Cruvinel et al., "Real-time evaluation of failure and reliability in agricultural sprayers using embedded sensors and controller area bus protocol", *International Journal on Advances in Systems and Measurements*, vol. 13, pp. 161-174, 2020.
- [6] K. S. Hatamleh et al., "Development of a specialinertial measurement unitfor UAV application", *Journal of Dynamic Systems, Measurement, and Control*, vol. 135, pp. 011003-011013, 2013.
- [7] R. I. Donahue, R. W. Miller and J. C. Shickluna, *Introduction to Soil and Plant Growth*, 5<sup>th</sup> Edition, Library of Congress: New York, USA, 1983.
- [8] J. R. Okalebo, K. W. Gathua and P. L. Woomer, *Laboratory methods of soil and plant analysis: a working manual*, 2<sup>nd</sup> Edition, Nairobi Tropical Soil Biology and Fertility Programme: Kenya, Africa, 2002.
- [9] F. Nüsslin, "Wilhelm Conrad Röntgen: The scientist and his discovery", *European Journal of Medical Physics*, vol. 79, pp. 65-68, 2020.
- [10] W. H. Bragg and W. L. Bragg, *X-rays and Crystal Structure*, Bell and Sons: London, England, 1915.
- [11] J. D. C. Pessoa et al., "Preparation of soil and plant samples for determination of macronutrients by X-ray fluorescence", in *Proceedings of the Symposium on the interaction of photons and electrons with matter (SAIFEM 96)*, São Carlos, SP, Brazil, pp. 9-10, 1996.
- [12] T. B. Johansson, R. Akselsson and S. A. E. Johansson, "X-ray analysis: Elemental trace analysis at the 10<sup>-12</sup> g level", *Nuclear Instruments and Methods*, vol. 84, pp. 141-143, 1970.
- [13] P. E. Cruvinel and R. G. Flocchini, "Determination of Se in soil samples using the proton induced X-ray emission technique". *Nuclear Instruments and Methods in Physics Research Section B*, vol. 75, pp. 415-419, 1993.
- [14] P. E. Cruvinel et al., "Elemental analysis of agricultural soil samples by particle induced X-ray emission (PIXE) technique", *Nuclear Instruments and Methods in Physics Research, Section B*, vol. 150, pp. 478-483, 1999.
- [15] A. Hessenbruch, "Rutherford's 1901 experiment on radiation energy and his creation of a stable detector", *Archives for the History of the Exact Sciences*, vol. 54, pp. 403-420, 2000.
- [16] A. Hessenbruch, "The origins of exact x-ray dosage", in *Proceedings of the Emergence of Modern Physics*, Università degli Studi di Pavia, pp. 81-87, 1996.
- [17] F. C. Miguens et al., "A new protocol to detect light elements in estuarine sediments by X-ray microanalysis (SEM/EDS)", *Journal of Electron Microscopy* vol. 59, issue 5, pp. 437-446, 2010.
- [18] C. Z. Zhou and W. K. Warburton, "Comparison of silicon pin diode detector fabrication processes using ion implantation

- and thermal doping”, Nuclear Instruments and Methods in Physics Research, Section A, vol. 378, issue 3, pp. 529-530, 1996.
- [19] K. Laqua et al., “Detection of radiation” Pure and Applied Chemistry, vol. 67, no. 10, pp. 1745-1760, 1995.
- [20] Tru-Q™ – Making accurate analysis a reality for all application: Available through the Oxford Instruments: [Online]. Available from: <http://www.oxinst.com/products/x-ray-microanalysis>.
- [21] D. Newbury, “X-ray Mapping in the Spectrum Image Mode at Output Count Rates above 100 kHz with the Silicon Drift Detector (SDD)”, Microscopy and Microanalysis vol. 12, pp. 1380-1381, 2006..
- [22] J. Y. Zevallos-Chavez et al., “Response function of a germanium detector to photon energies between 6 and 120 keV”, Nuclear Instruments and Methods in Physics Research, Section A, vol. 457, pp. 212-219, 2001.
- [23] G. Lioliou and A. M. Barnett, “Gallium Arsenide detectors for X-ray and electron (beta particle) spectroscopy”, Nuclear Instruments and Methods in Physics Research, Section A, vol. 836, issue 11, pp. 37-45, 2016.
- [24] D. Krasikov et al., “Why shallow defect levels alone do not cause high resistivity in CdTe”, Semiconductor Science and Technology, vol. 28, 125019 (7pp), 2013.
- [25] P. Lechner et al., “Silicon drift detectors for high count rate X-ray spectroscopy at room temperature”, Nuclear Instruments and Methods in Physics Research, Section A, vol. 458, issues 1–2, pp. 281-287, 2001.
- [26] H. Shirakawa et al., “Synthesis of electrically conducting organic polymers: halogen derivatives of Polyacetylene (CH)<sub>x</sub>”, Journal of the Chemical Society, Chemical Communications, vol. 16, pp. 578 - 580, 1977.
- [27] E. C. Venancio et al., “Line patterning of graphite and the fabrication of cheap, inexpensive, ‘throw-away’ sensors”, Sensors & Actuators, B: Chemical, vol. 130, pp. 723-729, 2008.